

- > **Port size:**
Flange PN 40
DN 15 ... 50
- > **For steam and hot water**
- > **Valve operates without differential pressure**
- > **Valve piston with PTFE guide-ring**



Technical features

Medium:

Neutral steam and liquid fluids

Switching function:

Normally closed

Mounting position:

Solenoid vertical on top;
optional up to G1 / 1 NPT;
solenoid underneath

Flow direction:

Determined

Port size:

DN 15, DN 20, DN 25, DN 32,
DN 40, DN 50

Operating pressure:

0 ... 16 bar (0 ... 232 psi)
0 ... 25 bar (0 ... 362 psi)

Fluid temperature:

0 ... +200°C (+32 ... +392°F)

Ambient temperature:

0 ... +60°C (+32 ... +140°F)

Approval depends on magnetic system, see pages 2!

Materials:

Body: Stainless steel (1.4408),
Brass
Seat seal: PTFE
Internal parts: Stainless steel,
PTFE-Carbon / FPM

For contaminated fluids insertion of a strainer is recommended.

Technical data - standard models

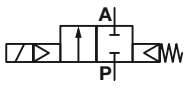
Symbol	Orifice	Operating pressure *2) *3)		Flow kv value *1)	Weight	Model	
	(mm)	(bar)	(psi)	(m³/h)	(kg)	Solenoid in V d.c.	Solenoid in V a.c.
	15	0 ... 16	0 ... 232	4.4	3,8	8652200.8402.xxxxx	8652200.8406.xxxxx
	20	0 ... 16	0 ... 232	6.5	4,2	8652300.8402.xxxxx	8652300.8406.xxxxx
	25	0 ... 16	0 ... 232	10	4,8	8652400.8402.xxxxx	8652400.8406.xxxxx
	32	0 ... 16	0 ... 232	22	9,6	8652500.8402.xxxxx	8652500.8406.xxxxx
	40	0 ... 16	0 ... 232	23	10	8652600.8402.xxxxx	8652600.8406.xxxxx
	50	0 ... 16	0 ... 232	37	11,5	8652700.8402.xxxxx	8652700.8406.xxxxx

xxxxx Please insert voltage and frequency codes

*1) Cv-value (US) ≈ kv value x 1,2

*2) For gases and liquid fluids up to 40 mm²/s (cSt)

*3) Lekrate E acc. to DIN EN 12266-1

Option selector

8652★ ★ ★ ★ ★ ★ ★ ★ ★ ★ ★ ★ ★ ★ ★ ★

Port size	Substitute
15	2
20	3
25	4
32	5
40	6
50	7
Valve options	Substitute
Normally open (NO)	01
Manual override	02
Seat seal EPDM, for hot water, Fluid temperature 0 ... +130°C (+32 ... +266°F)	14
Max. operating pressure 25 bar (362 psi)	22
Electrical position indicator with two limit switches (Reed contact)	23
Flanges acc.to ASME B 16.5 150 lb/sq.In.	47

Frequency	Substitute
See table frequency codes	xx
Voltage	Substitute
See Voltage codes	xxx
Solenoid options	Substitute
Solenoid in V d.c.	8402
Solenoid in V a.c.	8406

Standard solenoid systems

Voltage and Frequency Solenoid 8402/8406					
Code Voltage	Code Frequency	Voltage	Frequency	Inrush	Holding
024	00	24 V d.c.	-	29 W	29 W
024	50	24 V a.c. *1)	40 ... 60 Hz	33 VA	33 VA
110	50	110 V a.c. *1)	40 ... 60 Hz	33 VA	33 VA
120	60	120 V a.c. *1)	40 ... 60 Hz	33 VA	33 VA
230	50	230 V a.c. *1)	40 ... 60 Hz	33 VA	33 VA

*1) A.c. only with rectifier plug

Further versions on request!

Electrical details for all solenoid systems

Design	DIN VDE 0580
Voltage range	±10%
Duty cycle	100% ED
Protection class	EN 60529 IP65
Socket	Form A acc. to DIN EN 175301-803 (included)

According to DIN VDE 0580 at a solenoid temperature of +20°C. At operating state temperature the input power of a coil decreases by up to ca. 30% due to physical reasons.

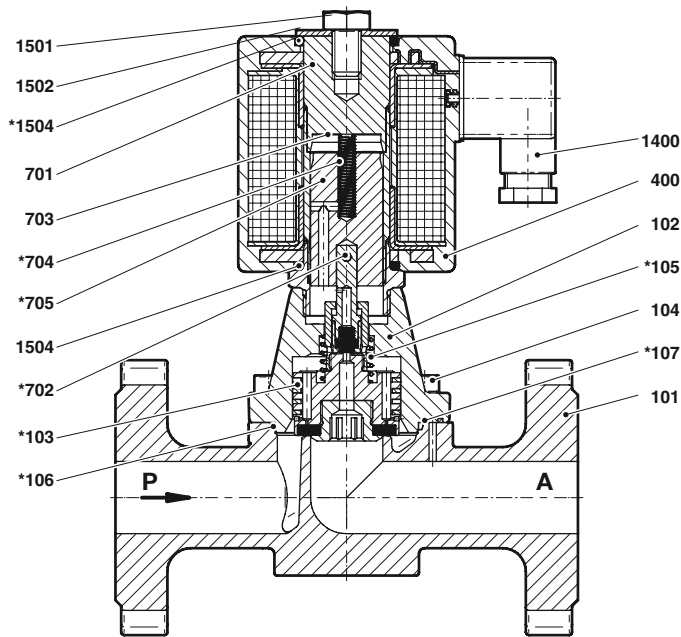
Section View
up to DN 25

No.	Description
101	Valve body
102	Valve cover
*103	Valve piston
104	Straight pin
*105	Pressure spring
*106	Seal ring
*107	Gaskets
400	Solenoid
701	Core tube
*702	Straight pin
703	Round plate
*704	Pressure spring
*705	Core
1400	Socket (included)
1501	Hexagon screw
1502	Round plate
*1504	O-Ring (2x)

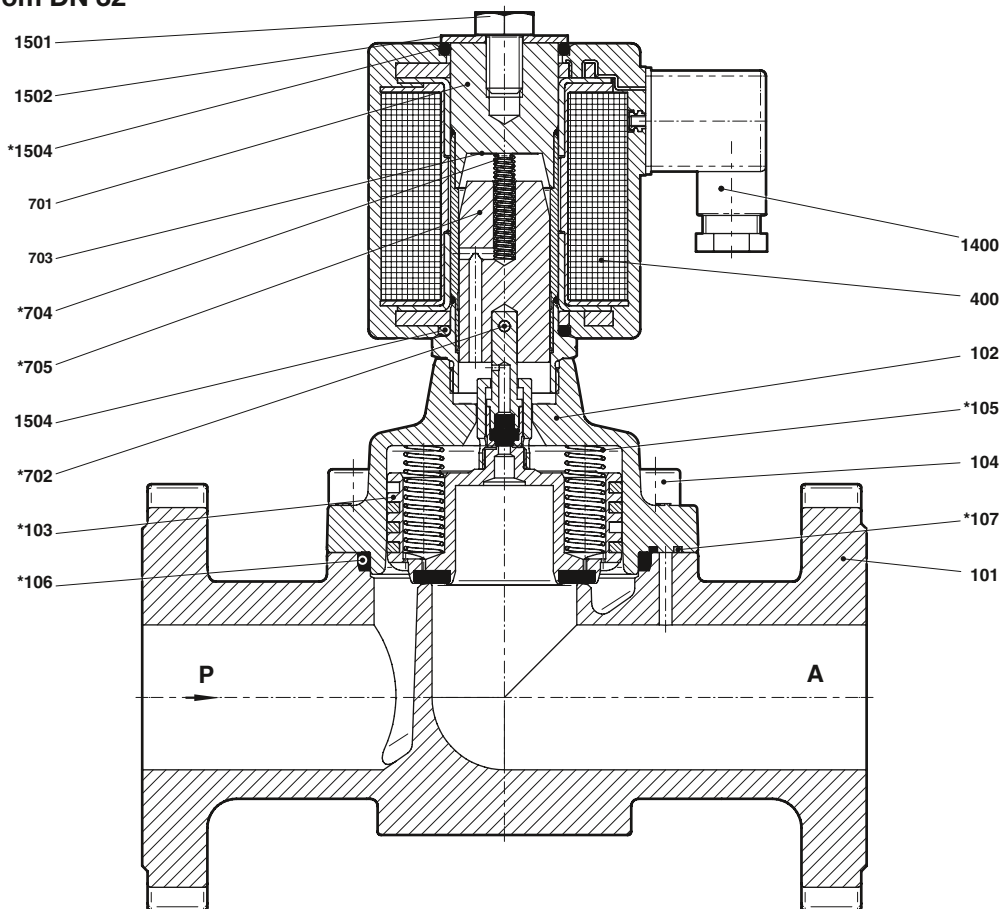
from DN 32

No.	Description
101	Valve body
102	Valve cover
*103	Valve piston
104	Straight pin
*105	Pressure spring (2x)
*106	Seal ring
*107	Gaskets
400	Solenoid
701	Core tube
*702	Straight pin
703	Round plate
*704	Pressure spring
*705	Core
1400	Socket (included)
1501	Hexagon screw
1502	Round plate
*1504	O-ring (2x)

* These individual parts form a complete wearing unit.
 When ordering spare parts please state Model No. and Series No.

Dimensions

DN 15 ... 50

Dimensions in mm
Projection/First angle

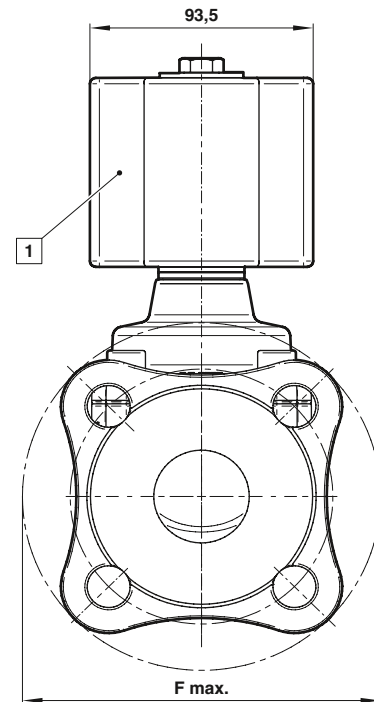
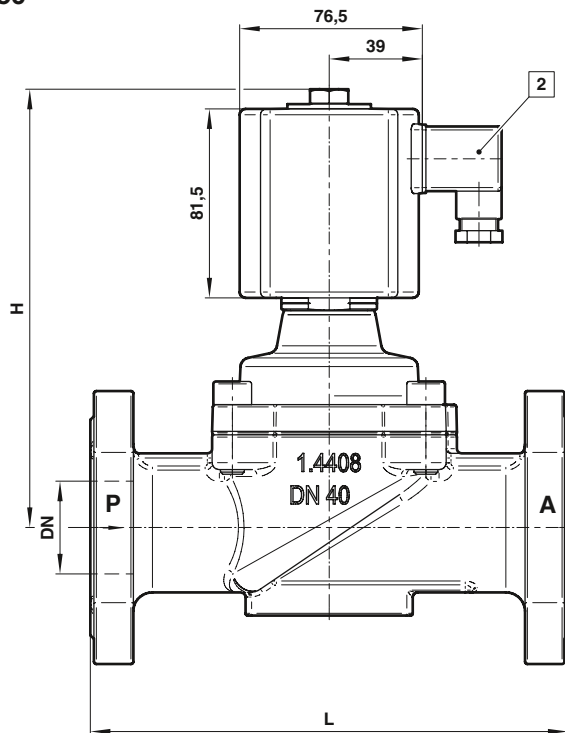

- 1 Solenoid rotatable 360°
- 2 Socket turnable 4 x 90°
(Socket included)

Orifice DN (mm)	ø F	H	L	Model
15	96	142	130	8652200.840x.xxxxx
20	110	150	150	8652300.840x.xxxxx
25	115	155	160	8652400.840x.xxxxx
32	140	184	180	8652500.840x.xxxxx
40	150	189	200	8652600.840x.xxxxx
50	165	197	230	8652700.840x.xxxxx

Suitable for assembly between flanges acc. to DIN EN 1092-1; Contact face acc. to DIN EN 1092-1/B

Note to Pressure Equipment Directive (PED):

The valves of this series, including the connection size DN 25 (G 1), are according to Art. 3 § 3 of the Pressure Equipment Directive (PED) 97/23/EG. This means interpretation and production are in accordance to engineers practice wellknown in the member countries. The CE-sign at the valve refers not to the PED. Thus the declaration of conformity is not longer applicable for this directive.

For valves > DN 25 (G 1) Art. 3 § (1) No.1.4 applies:

The basic requirements of the Enclosure I of the PED must be fulfilled. The CE-sign at the valve includes the PED. A certificate of conformity of this

directive will be available on request.

Note to Electromagnetic Compatibility Guideline (EEC):

The valves shall be provided with an electrical circuit which ensures the limits of the harmonised standards EN 61000-6-3 and EN 61000-6-1 are observed, and hence the requirements of the Electromagnetic Compatibility Guideline (2004/108/EG) satisfield.